

Making a home-made paintbox

by Ann Tucker



I am new to doing plein air painting. I went out recently with a Plein Air painting group. I brought my large set of Sennelier oil pastels in the original large box, a medium-size drawing board, an 11x14 pad of paper, a blanket to sit on, a tarp to go under the blanket and a small bag of assorted other stuff. By the time I walked from my car to where they were painting, I had two very aching shoulders. I stared enviously at the artist who had only carried a Guerilla-brand Thumb-box (about 8x10x4”) and a tripod. He didn’t look like his shoulders ached!

When I got home I looked around the internet at the available brands of these marvelous pochade boxes that hold everything with built-in easel. However, I found that most of them are made to hold paint tubes. They were small (which I liked) but they were deep. Since I want to see all my pastels at one time, the depth of the box was wasted space. I did eventually find one or two pochade boxes that would work nicely for pastels. However, the price was more than I wanted to spend. So I looked around WetCanvas.com for inspiration. I found an article about making a pochade box out of an old cigar box. That got me thinking and wandering through my local craft and hardware stores.

Oil Pastel Primer

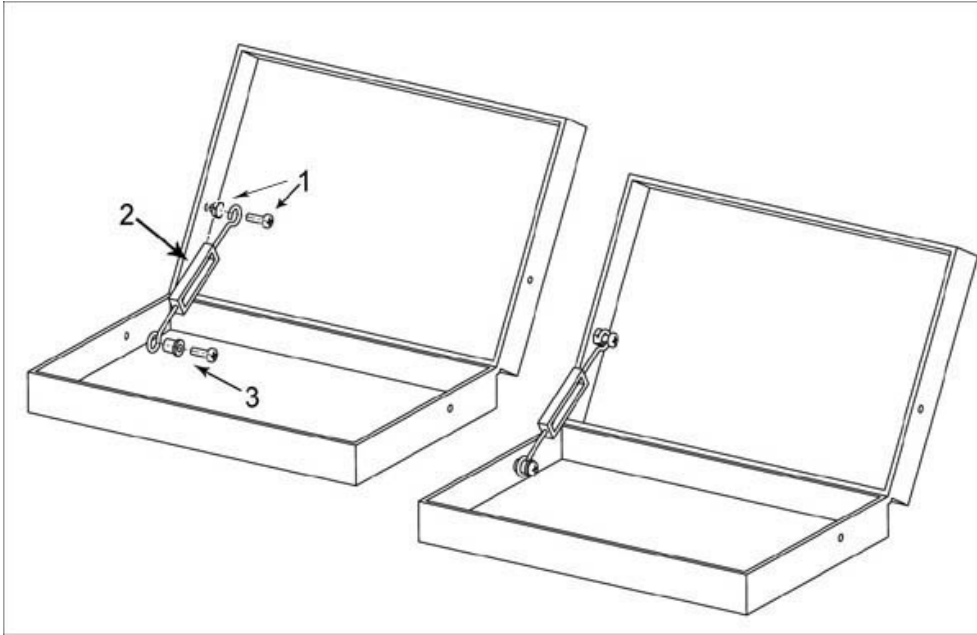

Here is my version of a home-made Pochade Box. I found this wooden box with metal hinges and metal clasps in the local craft store as a child's art kit filled with "intro to art" supplies. Item 1 is a screw and nut to act as a hook. Item 3 is a screw and plastic bushing to act as a pivot. Item 2 is something called a turn-buckle. Because it has a long screw-thread on each end it allows me a lot of adjustment. I have one turn-buckle on each side that I adjust to make sure I'm pushing against them equally. Item 4, my paper stop, is the little twist thing used to hold screen windows in place. It twists up to hold my 6x8" clipboard and pad of paper. This set up also nicely holds an 11x14 board with a piece of paper held to it with heavy-duty rubber bands (see first photo).

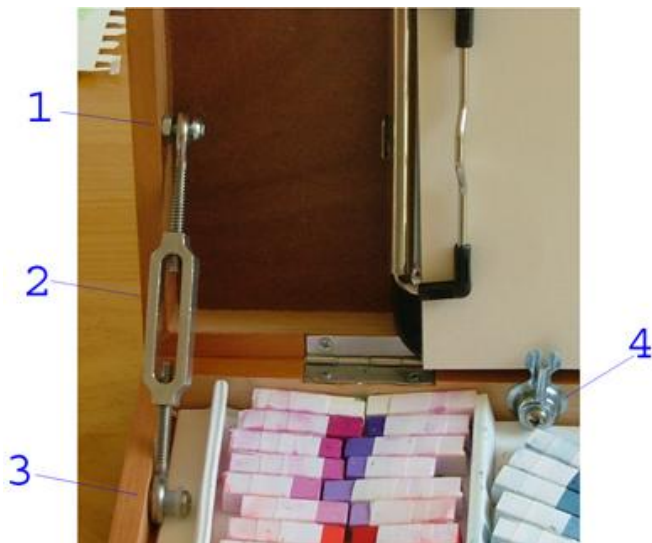

To close the box, the turn-buckles easily unhook from the top screws and the paper stops twists down. A thick pad of foam goes over the pastels to hold them in place, the clipboard with paper goes on top and the lid closes. I also added two "D-clips" on the sides to hook a shoulder strap to. Since the box was already

Oil Pastel Primer

made, the only tools I needed were a screwdriver and a drill. (I drilled holes into the wood slightly smaller than the screws to prevent the wood from splitting.)

For the inside, I used adhesive backed foam sheets from the craft store to line the box and make the dividers.

Total cost of this paint box was about US\$45 including the child's art kit.



When I used this to paint on location, what I carried from my car was reduced to this box, my Oil Pastel Society bag (<http://www.cafepress.com/oilpastels>) with paper towels, hat, garbage bag, etc., and a fold-up camp chair. When I arrive at the site, I sat in the chair, put the box on my lap and started painting. Life as a new plein air painter had just gotten a lot simpler!

